

TECHFLOW PRODUCTS

FREE
3rd Year Warranty
When Fitted with Techflange



QT PUMP RANGE INSTALLATION INSTRUCTIONS



***PLEASE READ THESE INSTRUCTIONS CAREFULLY BEFORE
PROCEEDING WITH THE INSTALLATION***

***FAILURE TO COMPLY COULD INVALIDATE YOUR WARRANTY AND
ADVERSELY AFFECT THE PERFORMANCE OF THE PUMP***

***IF YOU REQUIRE ANY FURTHER INFORMATION PLEASE CALL
THE TECHNICAL HELPLINE 01444 258017***

Tel: 01444 258003 (Sales & Enquiries) Fax: 01444 258004
E-mail: info@techflow.co.uk

www.techflow.co.uk

The TECHFLOW 'QT' range of **TWIN** centrifugal pumps with integral flow switches have been designed to boost pressure and flow from normal domestic tank fed supplies to mixing type shower valves and/or to other suitable terminal appliances / outlets in the house. Where baths, washing machines, dish washers and toilet cisterns need to be pumped using a twin ended pump a **bypass kit (27902) should also be fitted, available separately** (See Section 8). For further information on Whole House Pumping see our Technical Data Sheet No.4.

Twin ended pumps are designed to boost both hot and cold supplies to shower and /or other terminal appliances. It is essential to ensure that the **MINIMUM USABLE** cold water storage capacity is 225L (50 galls.) for the QT50 and QT80 pumps and 300L (70 galls.) for the QT120 and that the hot water capacity is adequate.

Techflow pumps are designed to comply with the United Kingdom water fitting bye laws scheme and all installations should be carried out by a competent person in accordance with the relevant Water Bye Laws and requirements of the Institute of Electrical Engineers.

This appliance is not intended for use by persons (including children) with reduced physical, sensory or mental capabilities, or lack of experience and knowledge, unless they have been given supervision or instruction concerning use of the appliance by a person responsible for their safety. Children should be supervised to ensure that they do not play with the appliance.

QT PUMP RANGE SPECIFICATIONS

MODEL	QT50	QT80	QT120
WEIGHT	4.5 KG	6.0 KG	8.0 KG
VOLTAGE	220/240 V	220/240 V	220/240 V
WATTS	300 W	490 W	740 W
FUSE RATING	5 A	5 A	5 A
IP RATING	IPx4	IPx4	IPx4
SPEED	2800 RPM	2800 RPM	2800 RPM
INSULATION CLASS	F	F	F
RATING	30MIN ON 30MIN OFF	30MIN ON 30MIN OFF	60MIN ON 30MIN OFF
CONNECTIONS	22 mm 'PUSH-IN' FLEXIBLE HOSES		
MAX. INLET PRESSURE	1.5 BAR (150 Pa)	1.5 BAR (150 Pa)	1.5 BAR (150 Pa)
MAX TOTAL HEAD	27m	37m	48m
MAX. INLET HOT TEMP.	65°C	65°C	65°C

QT PUMP RANGE SPECIFICATIONS

	QT50	QT80	QT120
A	165 mm	175 mm	220 mm
B	240 mm	300 mm	390 mm
C	280 mm	340 mm	430 mm
D	220 mm	220 mm	220 mm
E	180 mm	180 mm	180 mm
WIDTH	130 mm	130 mm	130 mm

INSTALLATION DETAILS

1 SITING

- 1.1 The pump must, for optimum performance, be sited as close as possible to and never more than 4 metres from the HOT WATER cylinder. The pump should always be sited **BELOW** the HOT WATER take-off from the cylinder. Where it is a requirement of the installation to sight a pump **ABOVE** the hot water take-off then we recommend either the TP or TURBO range of pumps.
- 1.2 A minimum gravity flow of 1 litre per minute is required on each side of the pump to activate the flow switches.
- 1.3 The pump must be mounted horizontally on it's four feet on a rigid level surface to facilitate adequate ventilation to the underside of the motor.
- 1.4 If installed in an unheated area, adequate protection against frost must be provided whilst maintaining ventilation to the pump motor.

2 PIPE WORK CONNECTIONS

- 2.1 Both HOT and COLD supplies must be dedicated / exclusive to the pump (i.e. not shared with other services).
- 2.2 The dedicated HOT WATER connection to the cylinder **MUST** be via a ¾ " anti - aeration flange. Only the following flange types should be used. These can be supplied by Techflow if required:
 QT50 side entry Techflange (Part No 27900) or top entry Techflange (Part No 27901)
 QT80 side entry Techflange (Part No 27900) or top entry Techflange (Part No 27901)
 QT120 side entry Techflange (Part No 27900)
 The SURREY or YORK flange types **MUST NOT** be used as they can restrict flow to the pump inlet.
- 2.3 The dedicated COLD WATER connection from the cold water storage tank should be positioned at least 25 mm (1 ") below the cold water supply pipe to the hot water cylinder. **NEVER CONNECT COLD WATER MAINS SUPPLIES DIRECTLY TO THE PUMP OR PLACE IT IN THE SAME LINE AS ANOTHER PRESSURE PUMP.**
- 2.4 The DOWN SERVICE from the cold water storage tank to the hot water cylinder should be made on the opposite side of the tank from the cold mains inlet (to minimise aeration to the pump) and run in 22 mm min. However, when the total demand from the hot water cylinder is likely to exceed 30 l/min, a 28 mm down service **MUST** be used. Typically, this will occur when two or more bathrooms are supplied from a common hot water cylinder.

- 2.5 Only PLASTIC TUBE or COPPER PIPE to relevant B.S. specification should be used - NEVER use stainless steel tube as this is not compatible with the 22 mm 'push-in' type fittings on the inlet/outlet flexible hoses. Wherever possible it is recommended that plastic tube is used as this will reduce even further any resonance or noise levels but adequate support should be provided.
- 2.6 Supplies to the pump inlets and the hot expansion / vent MUST be run in 22 mm (min) pipework. Downstream pipework should be 22 mm wherever possible but 15 mm can be used for short runs. However, this will result in reduced performance from the pump.
- 2.7 The flexible coupling hoses with 22 mm 'push-in' connectors supplied must be used in all installations. The pump should be sited in a position where these hoses are not bent or deflected by more than 30° from the vertical.
- 1) Hoses incorporating integral isolating valves should be applied to the inlet side of pump to satisfy servicing requirements.
 - 2) Standard hoses with no integral isolating valve should be applied to the outlet side of pump.
 - 3) Use correct tool for opening and closing integrated isolating valve to prevent damage. Please note these valves are of quarter turn design, rotate clockwise to close and anti-clockwise to open. Failure to comply to these instructions could lead to valve damage.
 - 4) **WARNING - pump must not run with valve closed.**

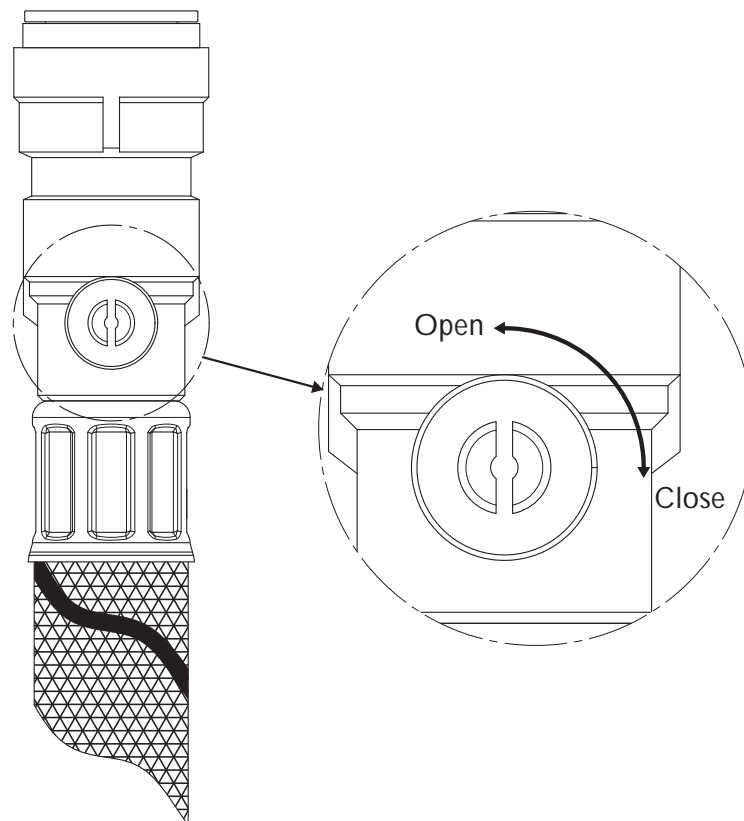

- 2.8 To remove the hoses from the pump or pipework hold the grey collet towards the fitting and pull off the hose.
NEVER MAKE DIRECT CONNECTIONS TO THE PLASTIC INLETS/ OUTLETS OF THESE PUMPS WITH COMPRESSION TYPE FITTINGS.
DO NOT install non return valves or devices which contain non-return valves, in the suction (inlet) pipework to the pump. The supply must be free to vent to the supply tank at all times.

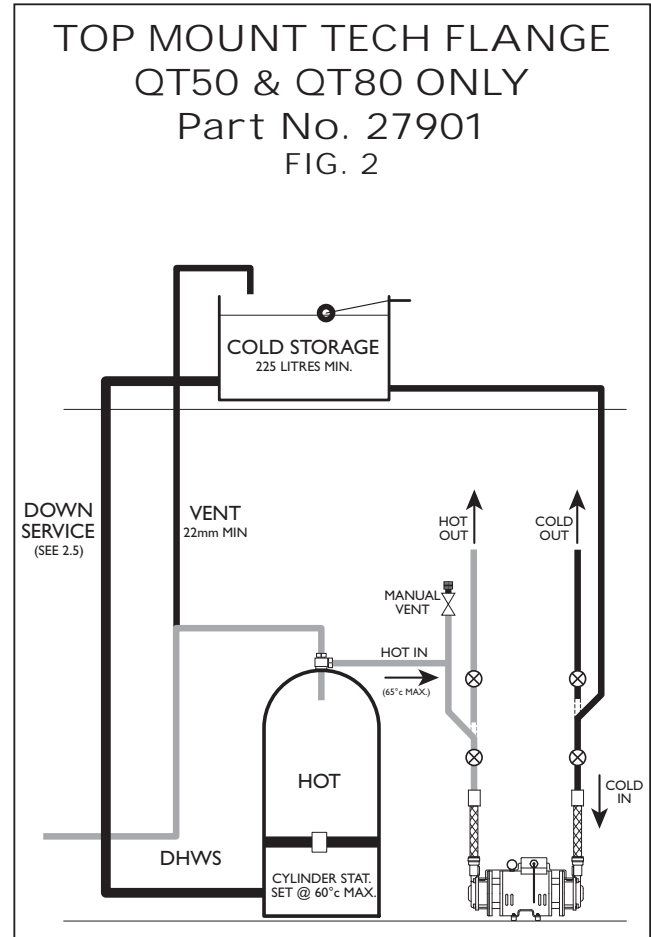
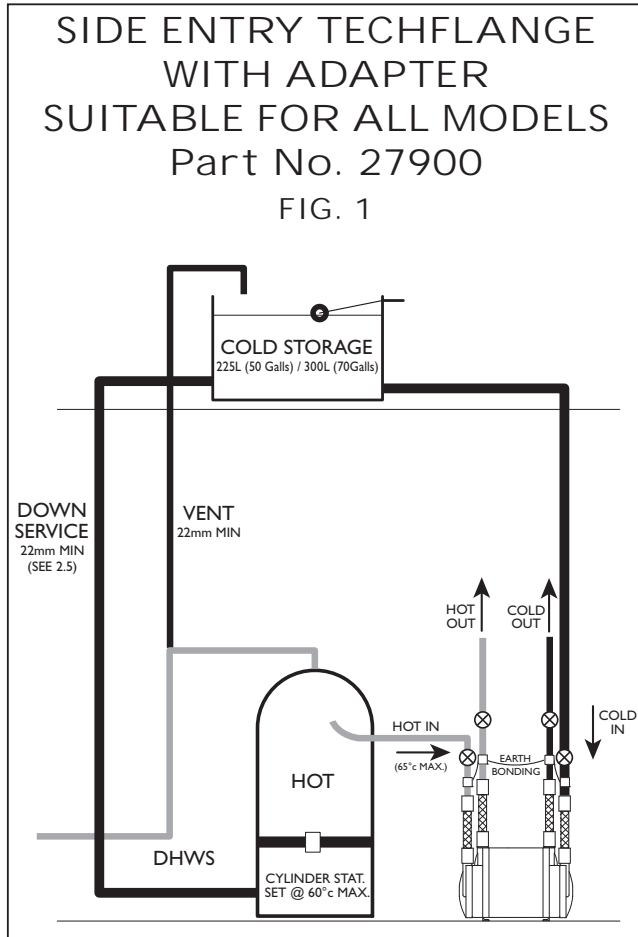

- 2.9 Either end of the pump can be used for hot or cold connection.
 2.10 Inlet filters are provided and must be fitted in every instance.
 2.11 All connecting pipes should be cut with a standard pipe cutter so that the pipe end is correctly finished prior to insertion into the flexible hose coupling . If any other tool is used to cut the pipe, the end of the pipe must be thoroughly deburred and chamfered before fitting. Also, check that the end is cut perpendicular to the length of the pipe.

A typical alternative outlet installation

In the case of horizontal feeds use a 22 mm compatible elbow (not supplied). Do not bend the hose more than 30° as they may become damaged, transmit noise or leak.

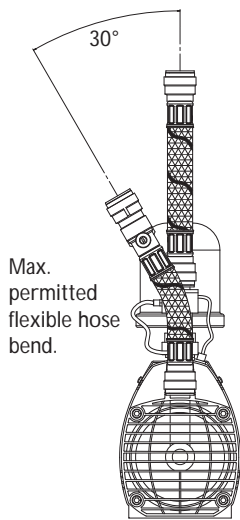
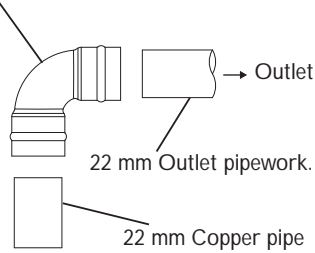

Do not kink or twist the hose.

22 mm Flexible pipe with push-in connections, always ensure connection is fully pushed home and that hoses are kept as straight as possible. Do not kink or twist the hose. Do not bend hose more than 30° as they may become damaged, transmit noise or leak.

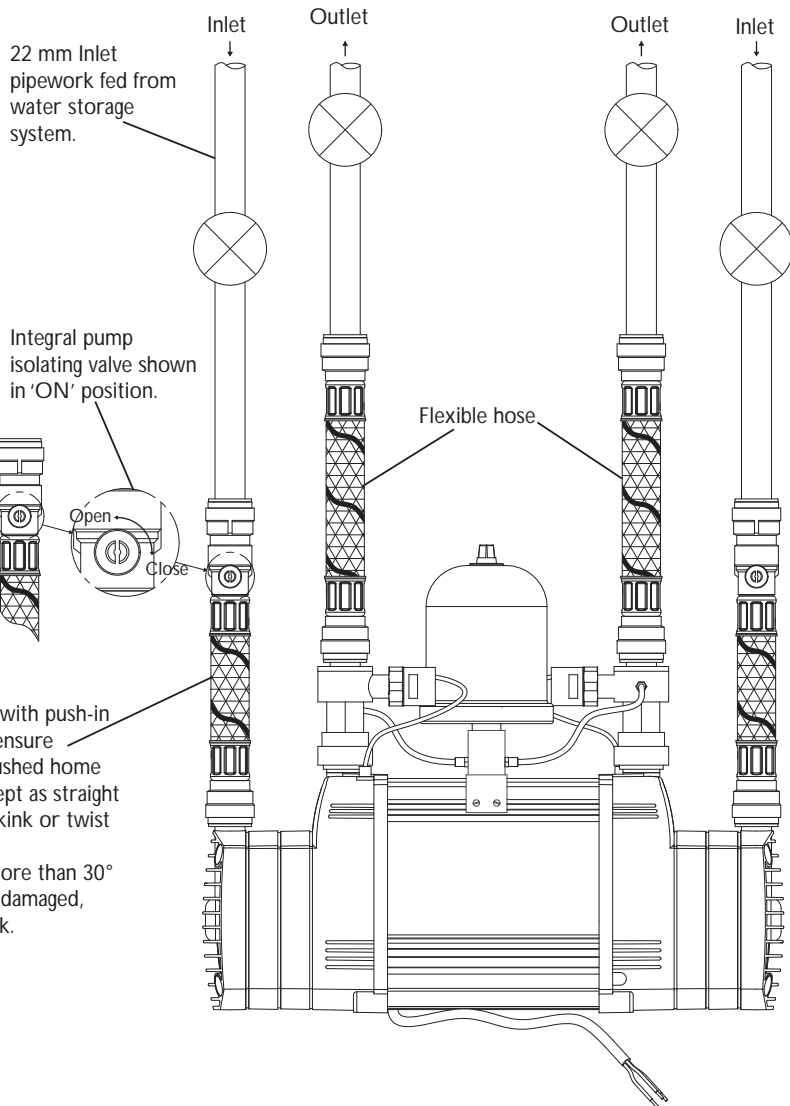
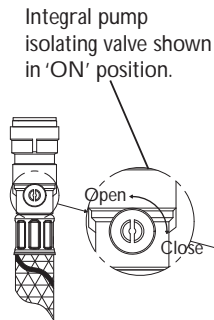

The pump should not be screwed down, ensure anti-vibration feet and flexible hoses are used.

3 ISOLATING VALVES

- 3.1 22 mm GATE TYPE or FULL - BORE LEVER OPERATED BALL TYPE isolating valves **MUST** be fitted to all inlets and outlets in an accessible position and as close to the pump as possible. **SERVICE CALLS WILL NOT BE UNDERTAKEN BY TECHFLOW PERSONNEL WHERE ISOLATING VALVES ARE NOT FITTED.**
- 3.2 Ballofix and other types of isolating valves **MUST NOT** be fitted as they can be restrictive resulting in starvation at the pump inlet and subsequent damage to the pump.

4 HOT WATER TEMPERATURE

- 4.1 The temperature of the hot supply **MUST NOT** exceed 65°C at the pump inlet. A cylinder stat. **MUST** be fitted to provide adequate temperature control and set to a **MAXIMUM** temperature of 60°C.
- 4.2 If a cylinder stat is not fitted and the temperature is to be controlled using a blending valve then either a **TP** or **Turbo** pump should be fitted.

5 ELECTRICAL INSTALLATION

THIS PUMP MUST BE EARTHED

- 5.1 The electrical installation **MUST** be undertaken by a competent person and **MUST** comply with the relevant IEE regulations.
- 5.2 All pipework must be cross bonded and an RCCB fitted in compliance with IEE regulations.

Copper or metallic pipework must have supplementary earth bonding where the continuity has been broken by flexible hoses or plastic components. Adjacent suction and delivery pipes should be fitted with earthing clamps to BS 951 and connected with earthing wire size 4 mm² as shown.

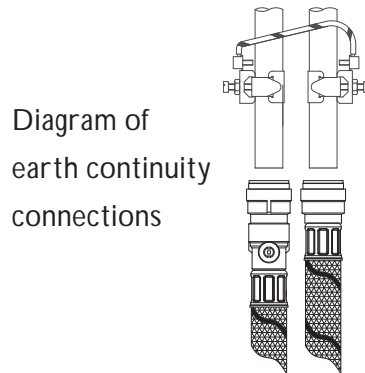

Certain installations may require additional earthing arrangements such as equipotential bonding. Reference should be made to the relevant regulations concerning this subject to ensure compliance.

- 5.3 The 240v supply should be taken via a fused spur from the ring main which must incorporate a switch to ensure that the pump can be disconnected from the supply.
- 5.4 Ensure that the correct fuse is fitted as shown in the specification table.
HIGHER RATED FUSES SHOULD NOT BE FITTED.
- 5.5 If the supply cord is damaged, it must be replaced by the manufacturer, its service agent or similarly qualified persons in order to avoid a hazard.

6 COMMISSIONING

- 6.1 The inlet pipework must be thoroughly flushed to purge the system of any swarf, traces of flux etc. **BEFORE** connection to the pump.
- 6.2 Having connected both inlet and outlet supplies open all isolating valves.
CHECK FOR LEAKS.
- 6.3 Open the shower valve or terminal fitting and allow water to flow through the system on GRAVITY for 2/3 minutes. With the shower valve still open switch on the power supply to the pump for 5/10 seconds and then switch off again. Allow a further 30 seconds of GRAVITY flow before switching the pump on to run for 10 seconds. Repeat this cycling until all air is purged from the system. Use the fitted manual finger vents to assist in purging the system.

NOTE: *If a flexible hose and handset shower system is installed remove the handset from the shower hose and lay the hose in the shower tray when purging the system. This ensures maximum gravity flow and will reduce the purging time.*

- 6.4 After initial commissioning of the system the isolating valves should be closed in order that the pump inlet filters can be removed, inspected and if necessary cleaned. Once reassembled the valves can be opened again.
NEVER ATTEMPT TO OPERATE A DRY PUMP AS THIS WILL CAUSE IRREPARABLE DAMAGE TO CRITICAL INTERNAL SEALS ETC.

7 WHOLE HOUSE PUMPING

Where a twin ended pump is to be used for pumping more than three low usage single temperature supply appliances a bypass kit part no. 27902 must be fitted to a standard QT Pump and this ensures that when one supply only is being pumped the opposite end of the pump, running against a closed outlet, maintains a low flow of water ensuring that the pump will not overheat and preventing subsequent damage.

8 NEGATIVE HEAD INSTALLATIONS

A Negative Head situation occurs when the level of cold water in the storage tank falls below the shower head outlet or other taps or appliances resulting in no gravity flow through the system or insufficient flow to operate the integral flow switches fitted in the standard QT pumps. **PLEASE NOTE THE REQUIREMENT FOR A MINIMUM 300 mm (12 ") GAP BETWEEN THE BOTTOM OF THE COLD WATER TANK AND THE PUMP INLETS STILL APPLIES.**

See *Sections 11-13* for installation of Negative Head Pumps.

9 SERVICING

TECHFLOW PUMPS ARE FACTORY SEALED UNITS AND THEREFORE SERVICING OR REPAIRS SHOULD ONLY BE CARRIED OUT BY TECHFLOW OR ITS AUTHORISED SERVICE AGENTS.

DISMANTLING THE PRODUCT WILL INVALIDATE YOUR WARRANTY.

10 'NHE' NEGATIVE HEAD SYSTEM INSTALLATION (SEE FIG. 3)

The 'NHE' Pressure Switch Assemblies activate the pump when the pressure in the system drops. This will occur when the shower valve or other outlet is opened. The unit will also prevent the pump from running dry in the event of water supply failure.

NOTE: Max. system head on QT50 NHE - 5 metres (0.5 bar)

Max. system head on QT80 NHE & QT120 NHE - 10 metres (1.0 bar)

IF THIS HEAD IS EXCEEDED THE PUMP WILL FAIL TO OPERATE

- 10.1 Push-in the two Pressure Switch Assemblies (1) to the OUTLET ports.
- 10.2 Ensure that the sealing washer is correctly located in the Manifold (5) and screw the Expansion Vessel (6) to the Manifold (5). **HAND TIGHTEN ONLY, IT IS ADVISABLE TO GRIP THE MANIFOLD WHILST TIGHTENING.**
- 10.3 Connect the blue tubing (7) to both the Manifold (5) and the Pressure Switch Assembly (1). Push the tubing over the fitting tail and tighten the knurled screw.
- 10.4 Push-in the Hoses (2) to the pump INLET ports and to the OUTLET connectors of the NHE Pressure Switch Assembly(1).
- 10.5 Thoroughly flush through the pipework and connect to complete the connections to the pump hoses. Isolating Valves (3) MUST be fitted to both inlet and outlet pipework.

NOTE: If Isolating Valves are NOT fitted to BOTH inlets and outlets then site visits will not be undertaken.

- 10.6 Connect the Pump Power Lead (4) to a fused spur ensuring that the correct rated fuse is fitted.

COMMISSIONING

- 10.7 Ensure that the power supply to the Pump is OFF.
- 10.8 Turn on the water supply to the pump.
- 10.9 Open the shower valve and allow 2 or 3 minutes for the water to reach the pump and for air to vent out of the system.
- 10.10 Turn on the power supply and the pump should now operate.

10.11 Allow the pump to run for several minutes to purge air from the system.

10.12 Close the shower valve and after a few seconds the pump will stop.

OPERATION

10.13 Opening the shower valve will automatically start the pump.

10.14 When the shower valve is closed the pump will run on for a few seconds before stopping. This is quite normal as the pressure in the pipework is being re-charged.

10.15 If the pump continues to stop/start with all outlets closed then check for leaks in the pipework.

NOTE: *On long pipe-runs it is possible that the pump will run for a short time every few hour to re-charge the system. This is quite normal.*

10.16 In the event of water supply failure or excessive aeration of the supply the pump will shut-down. Once the water supply is restored switch off the mains electrical supply to the pump, leave for a few seconds and then switch on again. This will re-set the pump which can then be operated normally.

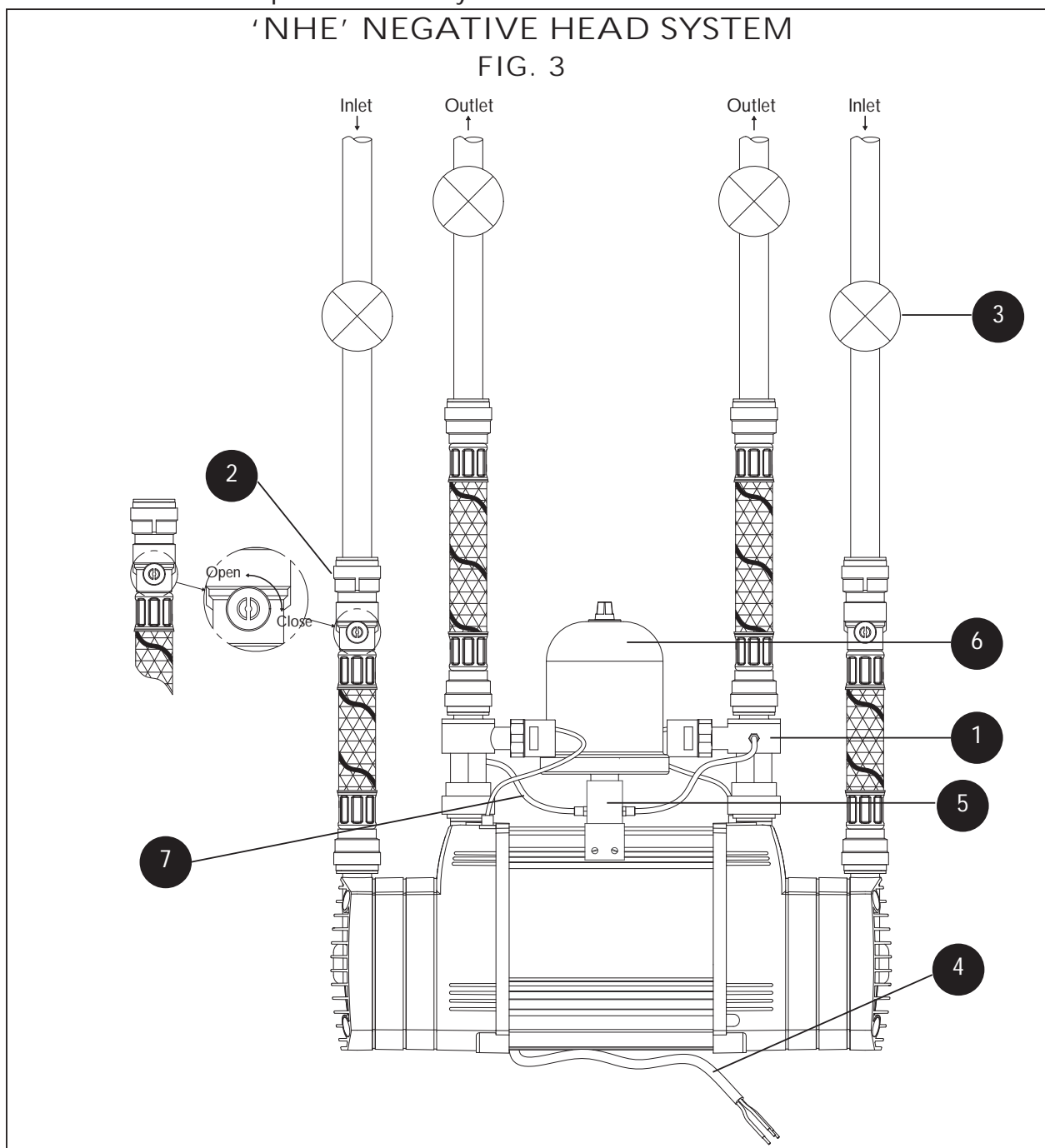

11 SINGLE ENDED PUMPS

The TECHFLOW 'QT' range of **SINGLE ENDED** centrifugal pumps have been designed to boost pressure and flow from normal domestic tank fed supplies to suitable terminal appliances / outlets in the house. Both flow-switch and pressure-switch (NH type) activated pumps are available and where two pumps are intended to boost hot and cold supplies to a shower mixer valve the NH range is recommended.

All pumps in the range are continuously rated and are designed to boost either hot or cold supplies. It is essential to ensure that both the hot and cold water storage capacity is adequate for the intended application. Each pump is capable of delivering up to 30 l/min (7 Galls/min). Please contact the Helpline for further advice.

INSTALLATION

- 11.1 Follow instructions as outlined in Sections 1-6 ensuring that dedicated supplies are maintained to the pump and that the correct type of anti-aeration flange is fitted where appropriate.
- 11.2 When the pump is fitted downstream of a shower mixer valve to boost blended flow fit as detailed in Fig.4. Ensure that the pipe run from the shower valve to the pump is in 22 mm and as short as possible.

Restrictive valves and systems can result in starvation to the pump inlet resulting in loss in performance. If in doubt consult the TECHFLOW Helpline.

QTSE PUMP RANGE SPECIFICATIONS

MODEL	QT50SE	QT80SE	QT120SE
WEIGHT	4.5 KG	5.0 KG	6.5 KG
VOLTAGE	220/240 V	220/240 V	220/240 V
WATTS	200 W	300 W	490 W
FUSE RATING	5 A	5 A	5 A
SPEED	2800 RPM	2800 RPM	2800 RPM
INSULATION CLASS	F	F	F
RATING	CONTINUOUS - FAN COOLED		
CONNECTIONS	22 mm 'PUSH-IN' FLEXIBLE HOSES		
MAX. INLET PRESSURE	1.5 BAR	1.5 BAR	1.5 BAR
MAX. INLET HOT TEMP.	65°C	65°C	65°C

QTSE PUMP RANGE SPECIFICATIONS

	QT50SE	QT80SE	QT120SE
A	165 mm	175 mm	220 mm
B	240 mm	300 mm	390 mm
C	280 mm	340 mm	430 mm
D	220 mm	220 mm	220 mm
E	180 mm	180 mm	180 mm
WIDTH	130 mm	130 mm	130 mm

SIDE MOUNTED TECHFLANGE

FIG. 4

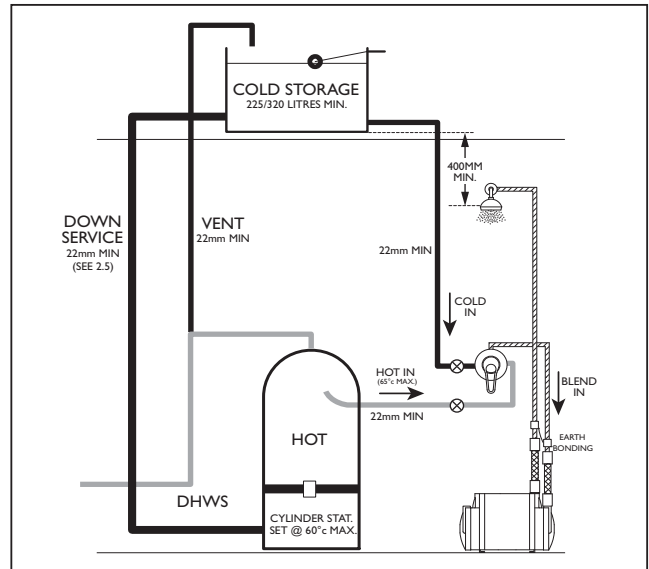

QT RANGE TWIN ENDED PUMP PERFORMANCE COMPARISONS

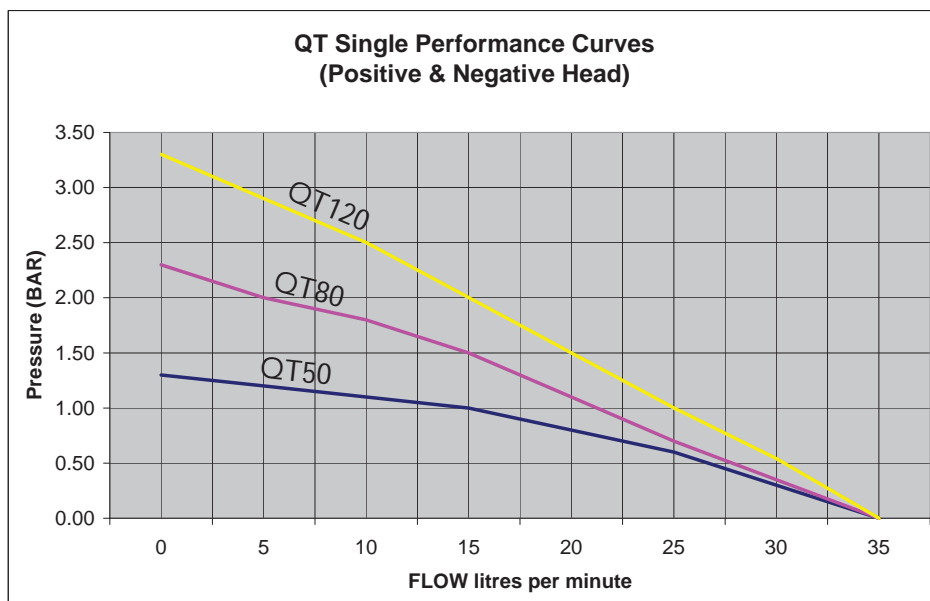
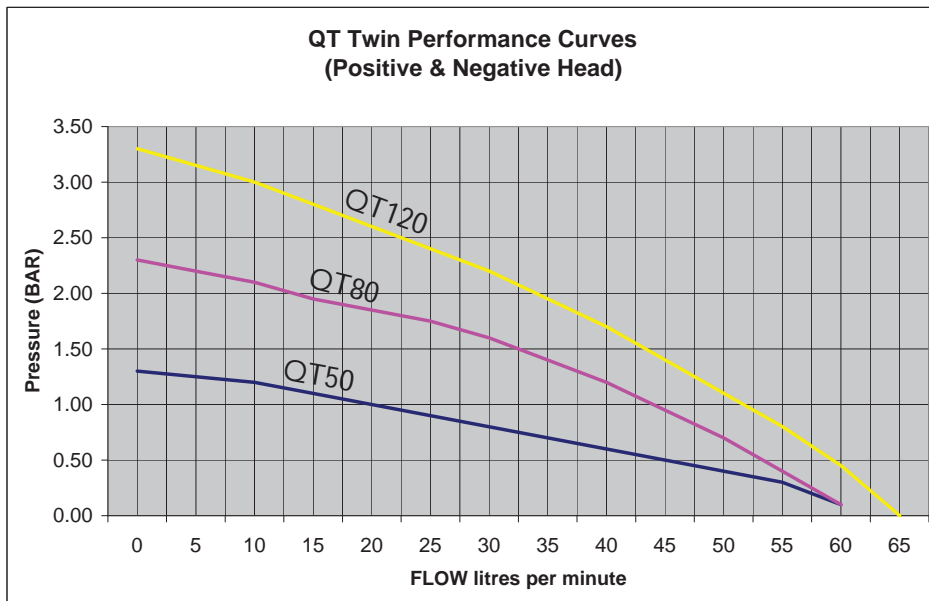

FAULT IDENTIFICATION TABLE

<i>SYMPTOM</i>	<i>PROBABLE CAUSE</i>	<i>RECOMMENDED SOLUTION</i>
1 PUMP WILL NOT START	1.1 INSUFFICIENT GRAVITY FLOW 1.2 ELECTRICAL 1.3 PUMP SEIZED	1.1 CHECK FLOW RATE MINIMUM OF 1 LITRE / MINUTE REQUIRED ON FULL HOT AND COLD 1.2 CHECK POWER SUPPLY CHECK FUSE CHECK CIRCUIT BREAKER 1.3 IF MOTOR "BUZZES" REMOVE POWER AND CONTACT TECHFLOW
2 REDUCED/ INTERMITTENT FLOW	2.1 INCORRECT OR NO ANTI-AERATION FLANGE FITTED 2.2 INCORRECT PIPE SIZES 2.3 BLOCKED INLET FILTERS 2.4 AIR IN SYSTEM 2.5 HOT TEMP. SET TOO HIGH	2.1 CHECK THAT THE INSTALLATION COMPLIES WITH INSTALLATION INSTRUCTIONS. SEE SECTION 2.2 2.2 CHECK THAT 22 mm PIPE WORK IS USED ON INLETS AND OUTLETS 2.3 CLEAN AND RE-TEST 2.4 RUN SYSTEM ON FULL HOT WITH PUMP SWITCHED OFF (I.E. GRAVITY ONLY) FOR SEVERAL MINUTES. CHECK THAT VENTS ARE FITTED AS DETAILED IN INSTRUCTIONS 2.5 REDUCE CYLINDER STAT SETTING TO 65°C MAX
3 PUMP RUNS ON WITH OUTLETS CLOSED	3.1 DEBRIS UNDER FLOW SWITCH 3.2 DAMAGED REED SWITCH	3.1 REMOVE OUTLET HOSES AND CHECK THAT FLOWSWITCH SITS IN LOWEST POSITION. 3.2 CONTACT TECHFLO
4 PUMP STARTS WITH ALL OUTLETS CLOSED	4.1 AIR IN SYSTEM 4.2 LEAK IN SYSTEM	4.1 SEE 2.4 ABOVE 4.2 CHECK ALL PIPE JOINTS AND APPLIANCES FOR LEAKS
5 FLEXIBLE HOSE LEAKS	5.1 NOT FITTED CORRECTLY 5.2 DAMAGED 'O' RINGS	5.1 CHECK THAT THE HOSE IS PUSHED FIRMLY ONTO THE PUMP INLET/OUTLET CONNECTORS AND PIPE WORK 5.2 CHECK COPPER PIPE ENDS ARE CLEANLY CUT AND DEBURRED

***IF YOU REQUIRE ANY FURTHER INFORMATION
PLEASE CALL THE TECHNICAL HELPLINE:***

01444 258017

TECHFLOW PRODUCTS LTD. WARRANTY STATEMENT

Thank you for buying one of our 'QT' range of pumps.

We are confident that the superior design and operating performance of our pump, combined with very high standards of manufacturing quality, will offer long operational life and product satisfaction.

The TERMS and CONDITIONS of the WARRANTY are:

1. The Scope of the Warranty

TECHFLOW PRODUCTS LTD. ('The Company') will, subject to the terms and conditions below and for the warranty period specified in paragraph 3, repair or replace free of charge any of its products that, in the opinion of the company, are defective because of faulty materials or workmanship. This warranty will not apply to any of the Company's product(s) that in the opinion of the company have been modified altered or misused in any way or where the products have been incorrectly installed or operated other than as described in the Company's 'Installation Instructions, or if any servicing or repair of the product(s) has been carried out by anyone other than our authorised Company Service Engineer or Dealer.

2. TERMS AND CONDITIONS

This Warranty is available to you on the following terms and conditions.

- 2.1 You are the original purchaser of the product(s) from an authorised dealer of the company ('The Dealer') and not an assignee or subsequent purchaser of the product(s).
- 2.2 You must provide evidence of the date of purchase of the product(s) by retaining the original invoice or receipt from the Dealer. Without such evidence the Company reserves the right to reject any claim under the terms of the Warranty.
- 2.3 Any alleged defect of the Company's product(s) giving rise to liability as stated in paragraph 1 must be advised to the Company within 30 days of discovery

3. THE WARRANTY PERIOD

- 3.1 This warranty will run for a period of 2 years from the date of purchase. If the pump is installed in compliance with Fig. 1 of these instructions using a side mounted **Techflange** the Warranty will be extended by one year to three years from the date of purchase.
- 3.2 The Warranty period in respect of any product(s) repaired or replaced under the terms of the Warranty shall be that part of the above 2 year period which remains unexpired.
4. In the event of a claim for repairs or replacement being made under the terms of the Warranty where, in the opinion of the Company, the defect has not been caused by the Company's materials or workmanship then the company reserves the right to charge the claimant at the hourly rates and list prices prevailing in respect of any service engineer's time and any replacement parts.
5. This Warranty is given in addition to and does not alter your statutory rights.
6. This Warranty is applicable only to products(s) purchased and used exclusively in the U.K.
For other territories refer to your Distributor for details of Warranty cover.
7. Where the company makes a replacement the product(s) replaced shall be returned to the Company immediately and shall become the property of the Company.
8. No authority has been given to any person, company or any other party to waive the terms of this Warranty.

NOTES

NOTES

Techflow Products

Service Department

Greys Road

Henley-on-Thames

Oxfordshire

RG9 1RY

plumbworld
Big brands, small prices.

Pdf Supplied By <http://www.plumbworld.co.uk/>